

Axle Shaft

Material

Item	Specification
Premium Long-Life Grease XG-1-C or XG-1-K (US); CXG-1-C (Canada)	ESA-M1C75-B

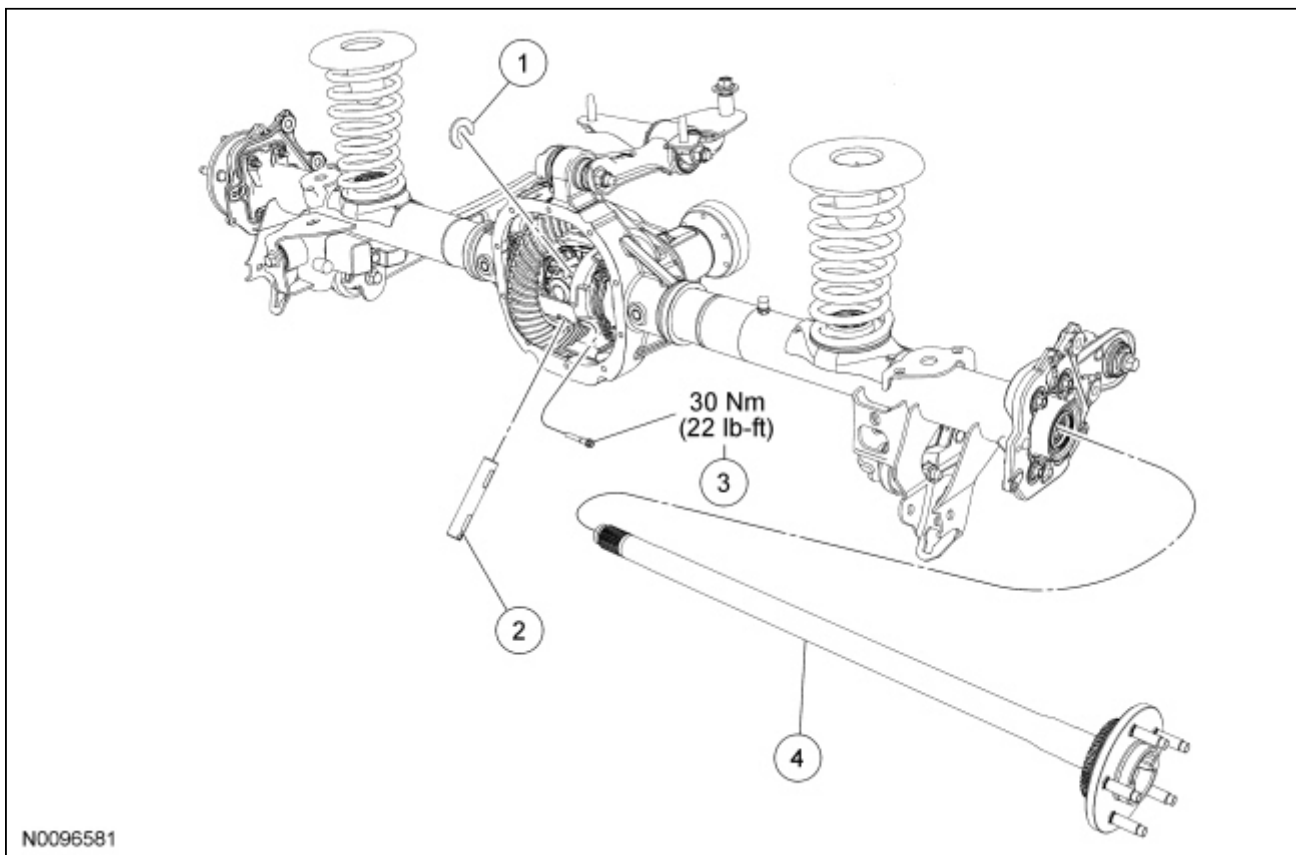

Item	Part Number	Description
1	4N237	Axle shaft U-washer
2	4211	Differential pinion shaft
3	4241	Differential pinion shaft lock bolt
4	4234	Axle shaft

Removal

1. With the vehicle in NEUTRAL, position it on a hoist. For additional information, refer to [Section 100-02](#).
2. Remove the differential housing cover. For additional information, refer to [Differential Housing Cover](#) in this section.
3. Remove the rear brake disc. For additional information, refer to [Section 206-04](#).

4. **NOTICE:** Damage to the rear wheel speed sensor may occur if it is not removed before the axle shaft U-washer.

Remove the bolt and position the rear wheel speed sensor aside.

5. Remove the differential pinion shaft.
1. Remove and discard the differential pinion shaft lock bolt.
 2. Remove the differential pinion shaft.

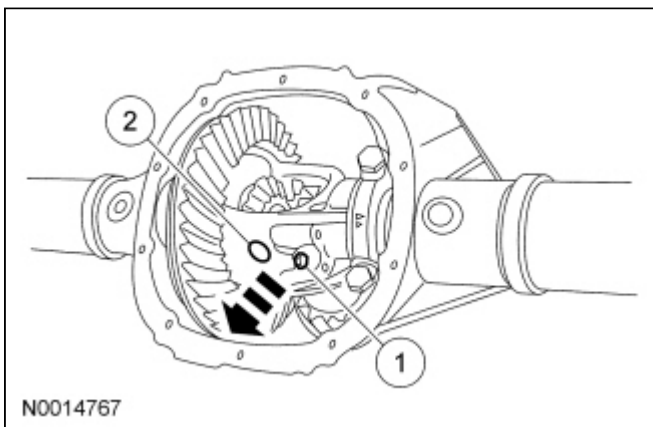

6. **NOTICE:** Do not damage the rubber O-ring in the axle shaft grooves.

Remove the axle shaft U-washer.

1. Push in on the axle shaft.
2. Remove the U-washer.

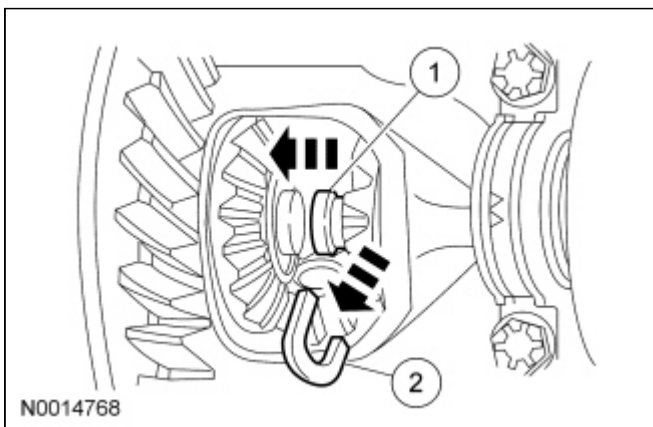

7. **NOTICE:** Do not damage the axle shaft oil seal.

Remove the axle shaft.

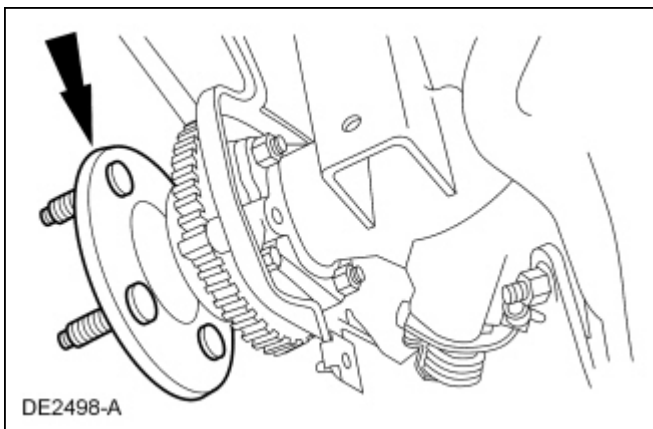

Installation

1. Lubricate the lip of the axle shaft oil seal with grease.
2. **NOTICE: Do not damage the axle shaft oil seal when installing the axle shaft.**

Install the axle shaft.

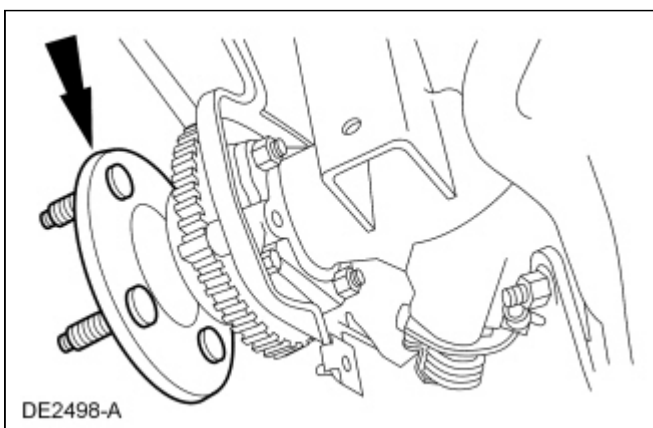

3. **NOTICE: Do not damage the rubber O-ring in the U-washer groove.**

Install the axle shaft U-washer.

1. Position the U-washer on the button end of the axle shaft.
2. Pull the axle shaft outward.

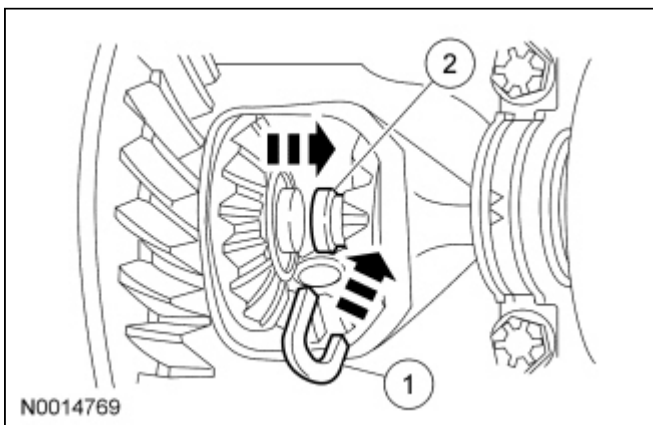

4. Install the differential pinion shaft.

- Align the hole in the differential pinion shaft with the differential case lock bolt hole.
- Install a new differential pinion shaft lock bolt.
 - Tighten to 30 Nm (22 lb-ft).

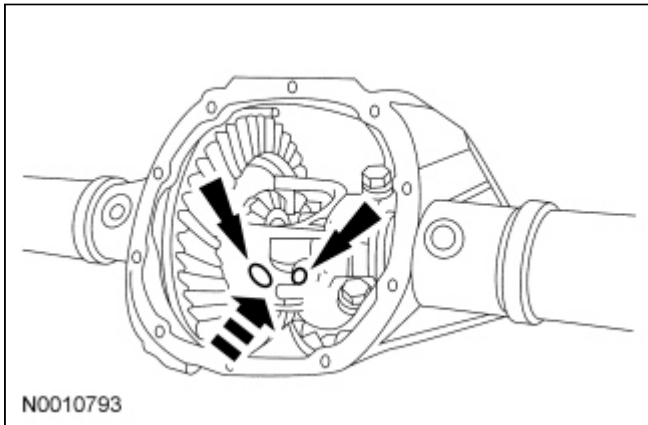

5. Position the rear wheel speed sensor and install the bolt.
 - Tighten to 15 Nm (133 lb-in).
 6. Install the rear brake disc. For additional information, refer to [Section 206-04](#).
 7. Install the differential housing cover. For additional information, refer to [Differential Housing Cover](#) in this section.
-